



Mag One<sup>™</sup> by Motorola  
Radio Series  
Basic Service Manual

6816101H01-A

---

## Computer Software Copyrights

The Motorola products described in this manual may include copyrighted Motorola computer programs stored in semiconductor memories or other media. Laws in the United States and other countries preserve for Motorola certain exclusive rights for copyrighted computer programs, including, but not limited to, the exclusive right to copy or reproduce in any form, the copyrighted computer program. Accordingly, any copyrighted Motorola computer programs contained in the Motorola products described in this manual may not be copied, reproduced, modified, reverse-engineered, or distributed in any manner without the express written permission of Motorola. Furthermore, the purchase of Motorola products shall not be deemed to grant, either directly or by implication, estoppel or otherwise, any license under the copyrights, patents or patent applications of Motorola, except for the normal non-exclusive license to use that arises by operation of law in the sale of a product.

---

## DOCUMENT HISTORY

The following major changes have been implemented in this manual since the previous edition:

Edition	Description	Date
6816101H01-A	Initial edition	Mar. 2007

---

## Notes

---

## Safety Information

### Product Safety and RF Energy Exposure Booklet for Portable Two-Way Radios

The information provided in this document supersedes the general safety information contained in user guides published prior to February 2002.

 <p><b>Caution</b></p>	<p>BEFORE USING THIS RADIO, READ THE FOLLOWING INFORMATION WHICH CONTAINS IMPORTANT OPERATING INSTRUCTIONS FOR SAFE USAGE AND RF ENERGY AWARENESS AND CONTROL INFORMATION AND OPERATIONAL INSTRUCTIONS FOR COMPLIANCE WITH RF ENERGY EXPOSURE LIMITS IN APPLICABLE NATIONAL AND INTERNATIONAL STANDARDS. ALSO READ THE OPERATIONAL INSTRUCTIONS FOR SAFE USAGE. FOR RADIOS THAT HAVE BEEN APPROVED AS INTRINSICALLY SAFE, READ THE INSTRUCTIONS AND INFORMATION ON INTRINSIC SAFETY ON PAGE vii.</p>
---	--

### RF Energy Exposure Awareness and Control Information and Operational Instructions for Occupational Use

**NOTICE:** This radio is intended for use in occupational/controlled conditions where users have full knowledge of their exposure and can exercise control over their exposure to meet the occupational limits in FCC and International standards. This radio device is NOT authorized for general population or consumer use.

This two-way radio uses electromagnetic energy in the radio frequency (RF) spectrum to provide communications between two or more users over a distance. It uses radio frequency (RF) energy or radio waves to send and receive calls. RF energy is one form of electromagnetic energy. Other forms include, but are not limited to, sunlight and x-rays. RF energy, however, should not be confused with these other forms of electromagnetic energy, which when used improperly, can cause biological damage. Very high levels of x-rays, for example, can damage tissues and genetic material.

Experts in science, engineering, medicine, health, and industry work with organizations to develop standards for safe exposure to RF energy. These standards provide recommended levels of RF exposure for both workers and the general public. These recommended RF exposure levels include substantial margins of protection.

All Motorola two-way radios are designed, manufactured, and tested to ensure they meet government-established RF exposure levels. In addition, manufacturers also recommend specific operating instructions to users of two-way radios. These instructions are important because they inform users about RF energy exposure and provide simple procedures on how to control it.

Please refer to the following websites for more information on what RF energy exposure is and how to control your exposure to assure compliance with established RF exposure limits:

<http://www.fcc.gov/oet/rfsafety/rf-faqs.html>

<http://www.osha.gov/SLTC/radiofrequencyradiation/index.html>

### Federal Communication Commission (FCC) Regulations

The FCC rules require manufacturers to comply with the FCC RF energy exposure limits for portable two-way radios before they can be marketed in the U.S. When two-way radios are used as a consequence of employment, the FCC requires users to be fully aware of and able to control their exposure to meet occupational requirements.

Exposure awareness can be facilitated by the use of a product label directing users to specific user awareness information. Your Motorola two-way radio has a RF exposure product label. Also, your Motorola user manual, or separate safety booklet includes information and operating instructions required to control your RF exposure and to satisfy compliance requirements.

## Compliance with RF Exposure Standards

Your Motorola two-way radio is designed and tested to comply with a number of national and International standards and guidelines (listed below) for human exposure to radio frequency electromagnetic energy. This radio complies with the IEEE (FCC) and ICNIRP exposure limits for occupational/controlled RF exposure environments at operating duty factors of up to 50% talk-50% listen and is authorized by the FCC for occupational use only.

In terms of measuring RF energy for compliance with these exposure guidelines, your radio generates measurable RF energy only while it is transmitting (during talking), not when it is receiving (listening) or in standby mode.

NOTE: The approved batteries, supplied with this radio, are rated for a 5-5-90 duty factor (5% talk-5% listen-90% standby) even though this radio complies with FCC occupational exposure limits and may operate at duty factors of up to 50% talk.

Your Motorola two-way radio complies with the following RF energy exposure standards and guidelines:

- United States Federal Communications Commission, Code of Federal Regulations; 47CFR part 2 sub-part J
- American National Standards Institute (ANSI) / Institute of Electrical and Electronic Engineers (IEEE) C95. 1-1992
- Institute of Electrical and Electronic Engineers (IEEE) C95.1-1999 Edition
- International Commission on Non-Ionizing Radiation Protection (ICNIRP) 1998
- Ministry of Health (Canada) Safety Code 6. Limits of Human Exposure to Radiofrequency Electromagnetic Fields in the Frequency Range from 3 kHz to 300 GHz, 1999
- Australian Communications Authority Radiocommunications (Electromagnetic Radiation - Human Exposure) Standard, 2003
- ANATEL ANNEX to Resolution No. 303 of July 2, 2002 "Regulation of limitation of exposure to electrical, magnetic and electromagnetic fields in the radio frequency range between 9 KHz and 300 GHz" and "Attachment to resolution # 303 from July 2, 2002"  
"Additional Requirements for SMR, Cellular and PCS Product Certification"

## RF Exposure Compliance and Control Guidelines and Operating Instructions

To control your exposure and ensure compliance with the occupational/controlled environment exposure limits, always adhere to the following procedures.

### Guidelines:

- Do not remove the RF Exposure Label from the device.
- User awareness instructions should accompany device when transferred to other users.
- Do not use this device if the operational requirements described herein are not met.

---

## Operating Instructions

- Transmit no more than the rated duty factor of 50% of the time. To transmit (talk), push the Push-To-Talk (PTT) button. To receive calls, release the PTT button. Transmitting 50% of the time, or less, is important because this radio generates measurable RF energy exposure only when transmitting (in terms of measuring for standards compliance).
- Hold the radio in a vertical position in front of the face with the microphone (and other parts of the radio including the antenna) at least one inch (2.5 centimeters) away from the nose or lips.
- Antenna should be kept away from the eye. Keeping the radio at a proper distance is important since RF exposures decrease with increasing distance from the antenna.
- When worn on the body, always place the radio in a Motorola-approved clip, holder, holster, case, or body harness for this product. Using approved body-worn accessories is important because the use of non-Motorola-approved accessories may result in exposure levels, which exceed the FCC occupational/controlled environment RF exposure limits.
- If you are not using a body-worn accessory and are not using the radio in the intended use position in front of the face, ensure the antenna and the radio are kept at least one inch (2.5 centimeters) from the body when transmitting. Keeping the radio at a proper distance is important because RF exposures decrease with increasing distance from the antenna.



## Approved Accessories

- Use only Motorola-approved supplied or replacement antennas, batteries, and accessories. Use of Non-Motorola approved antennas, batteries, and accessories may exceed the FCC (IEEE) and ICNIRP RF exposure guidelines.
- For a list of Motorola-approved accessories, visit the following website, which lists approved accessories for your radio model: <http://www.motorola.com/governmentandenterprise>.

## Additional Information

For additional information on exposure requirements or other training information, visit <http://www.motorola.com/rfhealth>.

## Electromagnetic Interference/Compatibility

NOTE: Nearly every electronic device is susceptible to electromagnetic interference (EMI) if inadequately shielded, designed, or otherwise configured for electromagnetic compatibility.

### Facilities

To avoid electromagnetic interference and/or compatibility conflicts, turn off your radio in any facility where posted notices instruct you to do so. Hospitals or health care facilities may be using equipment that is sensitive to external RF energy.

### Aircraft

When instructed to do so, turn off your radio when on board an aircraft. Any use of a radio must be in accordance with applicable regulations per airline crew instructions.

### Medical Devices

#### Pacemakers

The Advanced Medical Technology Association (AdvaMed) recommends that a minimum separation of 6 inches (15 centimeters) be maintained between a handheld wireless radio and a pacemaker. These recommendations are consistent with those of the U.S. Food and Drug Administration.

Persons with pacemakers should:

- ALWAYS keep the radio more than 6 inches (15 centimeters) from their pacemaker when the radio is turned ON.
- Not carry the radio in the breast pocket.
- Use the ear opposite the pacemaker to minimize the potential for interference.
- Turn the radio OFF immediately if there is any reason to suspect that interference is taking place.

## Hearing Aids

Some digital wireless radios may interfere with some hearing aids. In the event of such interference, you may want to consult your hearing aid manufacturer to discuss alternatives.

## Other Medical Devices

If you use any other personal medical device, consult the manufacturer of your device to determine if it is adequately shielded from RF energy. Your physician may be able to assist you in obtaining this information.

## Use of communication devices while driving

Always check the laws and regulations on the use of radios in the areas where you drive.

- Give full attention to driving and to the road.
- Use hands-free operation, if available.
- Pull off the road and park before making or answering a call, if driving conditions or regulations so require.

## Operational Warnings



For vehicle with air bags

Refer to vehicle manufacturer's manual prior to installation of electronic equipment to avoid interference with air bag wiring.

Do not place a portable radio in the area over an air bag or in the air bag deployment area. Air bags inflate with great force. If a portable radio is placed in the air bag deployment area and the air bag inflates, the radio may be propelled with great force and cause serious injury to occupants of the vehicle.

Potentially Explosive Atmospheres

(Explosive atmospheres refers to hazard classified locations that may contain hazardous gas, vapors, or dusts.)

Turn off your radio prior to entering any area with a potentially explosive atmosphere unless it is a portable radio type especially qualified for use in such areas as Intrinsically Safe (for example, Factory Mutual, CSA, UL, or CENELEC).

Do not remove, install, or charge batteries in such areas. Sparks in a potentially explosive atmosphere can cause an explosion or fire resulting in bodily injury or even death.

The areas with potentially explosive atmospheres referred to above include fueling areas such as below decks on boats, fuel or chemical transfer or storage facilities, and areas where the air contains chemicals or particles such as grain, dust or metal powders. Areas with potentially explosive atmospheres are often, but not always, posted.

Blasting Caps And Blasting Areas

To avoid possible interference with blasting operations, turn off your radio when you are near electrical blasting caps, in a blasting area, or in areas posted: "Turn off two-way radio." Obey all signs and instructions.



## Operational Cautions

 <b>Caution</b>	<p><b>Antennas</b></p> <p>Do not use any portable radio that has a damaged antenna. If a damaged antenna comes into contact with your skin, a minor burn can result.</p>
	<p><b>Batteries</b></p> <p>All batteries can cause property damage and/or bodily injury, such as burns, if a conductive material such as jewelry, keys, or beaded chains touches exposed terminals. The conductive material may complete an electrical circuit (short circuit) and become quite hot. Exercise care in handling any charged battery, particularly when placing it inside a pocket, purse, or other container with metal objects.</p>

## Intrinsically Safe Radio Information

The Intrinsically safe approval unit refers to a product that has been approved as intrinsically safe by an approval agency (for example FM Approvals, CSA, UL, or Cenelec) and certifies that a particular product meets the Agency's applicable intrinsic safety standards for specific types of hazardous classified locations. A portable radio that has been approved for intrinsic safety will have Approval label attached to the radio to identify the unit as being Approved for specified hazardous atmospheres. This label specifies the hazardous Class/Division/Group along with the part number of the battery that must be used. The intrinsically safe approval label will be located on the portable radio unit.

## Operational Cautions for Intrinsic Safe Equipment

 <b>Caution</b>	<ul style="list-style-type: none"> <li>• Do not operate radio communications equipment in a hazardous atmosphere unless it is a type especially qualified (for example, FM, UL, CSA, or CENELEC approved). An explosion or fire may result.</li> <li>• Do not operate a radio unit that has been approved as intrinsically safe product in a hazardous atmosphere if it has been physically damaged (for example, cracked housing). An explosion or fire may result.</li> <li>• Do not replace or charge batteries in a hazardous atmosphere. Contact sparking may occur while installing or removing batteries and cause an explosion or fire.</li> </ul>
---	--

## Warnings for Radios Approved as Intrinsically Safe

Radios must ship from the Motorola manufacturing facility with the hazardous atmosphere capability and the intrinsic safety approval labelling (FM, UL, CSA, CENELEC). Radios will not be upgraded to this capability and labeled once they have been shipped to the field.

A modification changes the unit's hardware from its original design configuration. Modifications can only be made by the original product manufacturer.



- Do not replace or change accessories in a hazardous atmosphere. Contact sparking may occur while installing or removing accessories and cause an explosion or fire.
- Turn the radio off before removing or installing a battery or accessory.
- Do not disassemble an intrinsically safe product in any way that exposes the internal circuits of the unit.
- Failure to use an intrinsically safe approved battery or Approved accessories specifically approved for the radio unit may result in the dangerously unsafe condition of an unapproved radio combination being used in a hazardous location.
- Unauthorized or incorrect modification of the intrinsically safe approved Product will negate the approval rating of the product.
- Incorrect repair or relabeling of any intrinsically safe Agency approved radio could adversely affect the Approval rating of the unit.
- Use of a radio that is not intrinsically safe in a hazardous atmosphere could result in serious injury or death.

## Repair



REPAIRS FOR MOTOROLA PRODUCTS WITH INTRINSICALLY SAFE APPROVAL ARE THE RESPONSIBILITY OF THE USER.

- Repairs to a Motorola FM approved radio product should only be done at a location that has been FM audited under the FM 3605 repairs and service standard.
- Contact Motorola for assistance regarding repairs and service of Motorola intrinsically safe equipment.

A repair constitutes something done internally to the unit that would bring it back to its original condition.

Items not considered as repairs are those in which an action is performed on a unit which does not require the outer casing of the unit to be opened in a manner that exposes the internal electrical circuits of the unit.

## Do Not Substitute Options or Accessories

The Motorola communications equipment certified as intrinsically safe by the approving agency, (FM, UL, CSA, CENELEC) is tested as a complete system which consists of the listed agency Approved portable, Approved battery, and Approved accessories or options, or both. This Approved portable and battery combination must be strictly observed. There must be no substitution of items, even if the substitute has been previously Approved with a different Motorola communications equipment unit. Approved configurations are listed by the Approving Agency (FM, UL, CSA, CENELEC).

The intrinsically safe Approval label affixed to radio refers to the intrinsically safe classification of that radio product, and the approved batteries that can be used with that system.

The manual PN referenced on the intrinsically safe approval label identifies the approved Accessories and or options that can be used with that portable radio unit.

Using a non Motorola intrinsically safe battery and or accessory with the Motorola approved radio unit will void the intrinsically safe approval of that radio unit.

---

# Table of Contents

Document History .....	i
Safety Information .....	iii
<b>Section 1      INTRODUCTION</b>	
1.0 Scope of Manual .....	1-1
2.0 Warranty and Service Support.....	1-1
2.1 Warranty Period and Return Instructions .....	1-1
2.2 After Warranty Period ... ..	1-2
2.3 Piece Parts .....	1-2
2.4 Technical Support .....	1-2
2.5 Further Assistance From Motorola .....	1-2
3.0 Radio Model Information.....	1-3
4.0 Radio Features .....	1-4
<b>Section 2      MAINTENANCE</b>	
1.0 Introduction .....	2-1
2.0 Preventive Maintenance .....	2-1
2.1 Inspection .....	2-1
2.2 Cleaning Procedures .....	2-1
3.0 Safe Handling of CMOS and LDMOS Devices .....	2-2
4.0 Repair Procedures and Techniques — General .....	2-3
5.0 Disassembling and Reassembling the Radio — General .....	2-4
6.0 Radio Disassembly — Detailed ... ..	2-5
6.1 Front Cover from Chassis Disassembly .....	2-5
6.2 PC Board Disassembly .....	2-8
7.0 Radio Reassembly — Detailed .....	2-8
7.1 PC Board Reassembly .....	2-8
7.2 Chassis and Front Cover Reassembly ... ..	2-9
8.0 Mechanical View and Parts List .....	2-12
8.1 Exploded View and Parts List.....	2-12
9.0 Service Aids .....	2-16
10.0 Test Equipment.....	2-17
11.0 Programming Cable (PMDN4043_R) .....	2-17
12.0 Cloning Cable (PMDN4060_R) .....	2-18
13.0 Test Box (PMDN4040_R) .....	2-18
<b>Section 3      RADIO TUNING</b>	
1.0 Introduction .....	3-1
2.0 Hardware Tuning Setup and Procedure .....	3-2

2.1 Tuning Frequency .....	3-2
2.2 Preparation Before Tuning (refer to Figure 3-1) .....	3-2
2.3 Transmitter Tuning .....	3-3
2.4 Receiver Tuning .....	3-6

## Section 4 RADIO PROGRAMMING

1.0 Introduction .....	4-1
2.0 Programming Your Radio .....	4-1
2.1 Overview of the Programming Process .....	4-1
2.2 Cloning Radio Parameters to User Radios .....	4-1
2.3 Parameters which are cloned .....	4-1
2.4 Parameters which are not cloned .....	4-1
2.5 To Clone a Radio .....	4-1
2.6 Error Conditions .....	4-2
3.0 CPS Programming .....	4-2
3.1 To Read Radio Data to a PC.....	4-3
3.2 To Write Data to a Radio .....	4-3
4.0 Factory Reset .....	4-3

## Section 5 ACCESSORIES

1.0 Antennas.....	5-1
2.0 Carry Accessories .....	5-1
3.0 Carry Cases .....	5-1
4.0 Chargers .....	5-1
5.0 Batteries.....	5-1
6.0 Audio Accessories .....	5-2
7.0 Publications .....	5-2
8.0 Service Kits .....	5-2

## Section 6 MODEL CHART AND TEST SPECIFICATION

1.0 VHF Band 1 Information (136-150 MHz) .....	6-1
2.0 Specifications.....	6-2
3.0 VHF Band 2 Information (150 - 174 MHz) .....	6-3
4.0 Specifications.....	6-4
5.0 UHF Band 1 Information (403-425MHz) .....	6-5
6.0 Specifications.....	6-6
7.0 UHF Band 2 Information (450 - 470MHz) .....	6-7
8.0 Specifications.....	6-8
9.0 UHF Band 4 Information (490 - 512 MHz) .....	6-9
10.0 Specifications.....	6-10

Glossary of Terms .....	G-1
-------------------------	-----

# Section 1

## INTRODUCTION

### 1.0 Scope of Manual

This manual is intended for use by service technicians familiar with similar types of equipment. It contains service information required for the equipment described and is current as of the printing date. Changes which occur after the printing date may be incorporated by a complete Manual revision or alternatively as additions.

**NOTE** Before operating or testing these units, please read the Safety Information Section in the front of this manual.

### 2.0 Warranty and Service Support

Motorola offers long term support for its products. This support includes full exchange and/or repair of the product during the warranty period, and service/ repair or spare parts support out of warranty. Any "return for exchange" or "return for repair" by an authorized Motorola Dealer must be accompanied by a Warranty Claim Form. Warranty Claim Forms are obtained by contacting an Authorized Motorola Dealer.

#### 2.1 Warranty Period and Return Instructions

The terms and conditions of warranty are defined fully in the Motorola Dealer or Distributor or Reseller contract. These conditions may change from time to time and the following notes are for guidance purposes only.

In instances where the product is covered under a "return for replacement" or "return for repair" warranty, a check of the product should be performed prior to shipping the unit back to Motorola. This is to ensure that the product has been correctly programmed or has not been subjected to damage outside the terms of the warranty.

**NOTE** For service technicians in the Latin America Countries Region  
For any warranty claims in the Latin America Countries region, please open a case using the "Contact Us" feature within Motorola Online at <https://businessonline.motorola.com/>.

Prior to shipping any radio back to the appropriate Motorola warranty depot, please contact Customer Resources (Please see page 1-2). All returns must be accompanied by a Warranty Claim Form, available from your Customer Services representative. Products should be shipped back in the original packaging, or correctly packaged to ensure no damage occurs in transit.

## 2.2 After Warranty Period

**NOTE** For service technicians in the Latin America Countries Region  
After Warranty Period claims in the Latin America Countries region are handled through the Motorola Authorized Service Provider (SAM) Network. To find the nearest SAM, please go to Motorola Resource Center in Motorola Online at <https://businessonline.motorola.com/> .

After the Warranty period, Motorola continues to support its products in two ways.

1. Motorola's Managed Technical Services (MTS) offers a repair service to both end users and dealers at competitive prices.
2. MTS supplies individual parts and modules that can be purchased by dealers who are technically capable of performing fault analysis and repair.

## 2.3 Piece Parts

**NOTE** For service technicians in the Latin America Countries Region  
All part orders should be directed to your local Parts Distributors.

Some replacement parts, spare parts, and/or product information can be ordered directly. If a complete Motorola part number is assigned to the part, it is available from Motorola's Managed Technical Services (MTS). If no part number is assigned, the part is not normally available from Motorola. If the part number is appended with an asterisk, the part is serviceable by Motorola Depot only. If a parts list is not included, this generally means that no user-serviceable parts are available for that kit or assembly.

All orders for parts/information should include the complete Motorola identification number. All part orders should be directed to your local MTS office. Please refer to your latest price pages.

## 2.4 Technical Support

**NOTE** For service technicians in the Latin America Countries Region  
For Technical Support in the Latin America Countries Region, please open a case using the "Contact Us" feature within Motorola Online at <https://businessonline.motorola.com/> .

Technical support is available to assist the dealer/distributor in resolving any malfunction which may be encountered. Initial contact should be by telephone wherever possible. When contacting Motorola Technical Support, be prepared to provide the product model number and the unit's serial number.

## 2.5 Further Assistance From Motorola

You can also contact the Customer Help Desk through the following web address:  
<http://www.motorola.com/governmentandenterprise/contactus>

**NOTE** Only Motorola Service Centers or Approved Motorola Service Dealers can perform these functions. Any tampering by non-authorized Motorola Service Centers voids the warranty of your radio. To find out more about Motorola and its approved Service Centers, please visit <http://www.motorola.com/governmentandenterprise/public/functions/home/home.aspx>

### 3.0 Radio Model Information

The model number and serial number are located on a label attached to the back of your radio. You can determine the RF output power, frequency band, protocols, and physical packages. The example below shows one portable radio model number and its specific characteristics.

Table 1-1 Radio Model Number (Example: LAH84JDC8AA4)

	Type of Unit	Model Series	Freq. Band	Power Level	Physical Packages	Channel Spacing	Protocol	Feature Level
LA	H	84	J (136-150 MHz)	D 5W	C 16-Channel Black	8 12.5/25K	AA Conventional	4 A8
			K (150-174 MHz)	C 4W				
			Q (403-425 MHz)					
			R (450-470 MHz)					
			T (490-512 MHz)					

H = Portable  
 LA = Latin America Regional Prefix

## 4.0 Radio Features

The following are features your radio has.

### Normal Operation

- . Rx/Tx
- . Radio-CPS-Radio Cloning
- . Radio-to-Radio Cloning
- . Factory Reset
- . Low Battery Indication
- . Self Test

### Programming Button

- . Hi/Lo Power
- . Volume Set
- . Monitor
- . Sticky Monitor
- . Scan Activate
- . Nuisance Channel Delete
- . Repeater/Talkaround
- . PL/DPL
- . Button Lock
- . Battery Save Mode
- . Squelch
- . Unassigned

### CPS

- . Rx Frequency
- . Tx Frequency
- . RX TPL/DPL/IDPL
- . TX TPL/DPL/IDPL
- . User Defined PL (TPL1, TPL2, TPL3)
- . Squelch Type
- . Unmute/Mute Rules
- . Power Level (High/Low)
- . TPL Reverse Burst
- . Turn Off Code
- . Rx Only
- . Busy Channel Lock Out (BCLO)
- . Channel Spacing (25KHz / 12.5KHz)
- . Talkaround
- . Time Out Timer
- . Battery Save Mode
- . Quick Key Override
- . Password Protection
- . Scan List
- . Normal Scan
- . Priority Scan
- . Talkback Scan



---

## Section 2

# MAINTENANCE

### 1.0 Introduction

This chapter provides details about the following:

- Preventive Maintenance
- Safe Handling of CMOS and LDMOS Devices
- General Repair Procedures and Techniques
- Disassembling and Reassembling the Radio

### 2.0 Preventive Maintenance

Periodic visual inspection and cleaning is recommended.

#### 2.1 Inspection

Check that the external surfaces of the radio are clean, and that all external controls and switches are functional. It is not recommended to inspect the interior electronic circuitry.

#### 2.2 Cleaning Procedures

The following procedures describe the recommended cleaning agents and the methods to be used when cleaning the external and internal surfaces of the radio. External surfaces include the front cover, housing assembly and battery case. These surfaces should be cleaned whenever a periodic visual inspection reveals the presence of smudges, grease, and/or grime.

**NOTE** Internal surfaces should be cleaned only when the radio is disassembled for service or repair.

The only recommended agent for cleaning the external radio surfaces is a 0.5% solution of a mild dishwashing detergent in water. The only factory recommended liquid for cleaning the printed circuit boards and their components is isopropyl alcohol (70% by volume).



**CAUTION:** The effects of certain chemicals and their vapors can have harmful results on certain plastics. Avoid using aerosol sprays, tuner cleaners, and other chemicals.

#### Cleaning External Plastic Surfaces

Apply the 0.5% detergent-water solution sparingly with a stiff, non-metallic, short-bristled brush to work all loose dirt away from the radio. Use a soft, absorbent, lintless cloth or tissue to remove the solution and dry the radio. Make sure that no water remains entrapped near the connectors, cracks, or crevices.

### Cleaning Internal Circuit Boards and Components

Isopropyl alcohol (70%) may be applied with a stiff, non-metallic, short-bristled brush to dislodge embedded or caked materials located in hard-to-reach areas. The brush stroke should direct the dislodged material out and away from the inside of the radio. Make sure that controls or tunable components are not soaked with alcohol. Do not use high-pressure air to hasten the drying process since this could cause the liquid to collect in unwanted places. After completing of the cleaning process, use a soft, absorbent, lintless cloth to dry the area. Do not brush or apply any isopropyl alcohol to the frame, front cover, or back cover.

**NOTE** Always use a fresh supply of alcohol and a clean container to prevent contamination by dissolved material (from previous usage).

## 3.0 Safe Handling of CMOS and LDMOS Devices

Complementary metal-oxide semiconductor (CMOS) devices are used in this family of radios, and are susceptible to damage by electrostatic or high voltage charges. Damage can be latent, resulting in failures occurring weeks or months later. Therefore, special precautions must be taken to prevent device damage during disassembly, troubleshooting, and repair.

Handling precautions are mandatory for CMOS circuits and are especially important in low humidity conditions. **DO NOT** attempt to disassemble the radio without first referring to the following **CAUTION** statement.



**CAUTION:** This radio contains static-sensitive devices. Do not open the radio unless you are properly grounded. Take the following precautions when working on this unit:

- Store and transport all CMOS devices in conductive material so that all exposed leads are shorted together. Do not insert CMOS devices into conventional plastic “snow” trays used for storage and transportation of other semiconductor devices.
- Ground the working surface of the service bench to protect the CMOS device. We recommend using the Motorola Static Protection Assembly (part number 0180386A82), which includes a wrist strap, two ground cords, a table mat, and a floor mat.
- Wear a conductive wrist strap in series with a 100k resistor to ground. (Replacement wrist straps that connect to the bench top covering are Motorola part number RSX-4015.)
- Do not wear nylon clothing while handling CMOS devices.
- Do not insert or remove CMOS devices with power applied. Check all power supplies used for testing CMOS devices to be certain that there are no voltage transients present.
- When straightening CMOS pins, provide ground straps for the apparatus used.
- When soldering, use a grounded soldering iron.
- If at all possible, handle CMOS devices by the package and not by the leads. Prior to touching the unit, touch an electrical ground to remove any static charge that you may have accumulated. The package and substrate may be electrically common. If so, the reaction of a discharge to the case would cause the same damage as touching the leads.

## 4.0 Repair Procedures and Techniques — General

### Parts Replacement and Substitution

When damaged parts are replaced, identical parts should be used. If the identical replacement part is not locally available, check the parts list for the proper Motorola part number and order the part from the nearest Motorola Communications parts center listed in the Piece Parts section of this manual.

### Rigid Circuit Boards

This family of radios uses bonded, multi-layer, printed circuit boards. Since the inner layers are not accessible, some special considerations are required when soldering and unsoldering components. The printed-through holes may interconnect multiple layers of the printed circuit. Therefore, exercise care to avoid pulling the plated circuit out of the hole.

When soldering near the 20-pin and 40-pin connectors:

- Avoid accidentally getting solder in the connector.
- Be careful not to form solder bridges between the connector pins.
- Examine your work closely for shorts due to solder bridges.

### Flexible Circuits

The flexible circuits are made from a different material than the rigid boards, and require different soldering techniques. Excessive prolonged heat on a flexible circuit can damage the material. Therefore, avoid excessive heat and excessive bending.

For parts replacement, use the ST-1087 Temperature-Controlled Solder Station with a 600-700 degree F tip, and use small diameter solder such as ST-633. The smaller size solder will melt faster and require less heat to be applied to the circuit.

To replace a component on a flexible circuit:

1. Grasp with seizers (hemostats) the edge of the flexible circuit near the part to be removed.
2. Pull gently.
3. Apply the tip of the soldering iron to the component connections while pulling with the seizers.

**NOTE** Do not attempt to puddle-out components. Prolonged application of heat may damage the flexible circuit.

### Chip Components

Use either the RLN-4062 Hot-Air Repair Station or the Motorola 0180381B45 Repair Station for chip component replacement. When using the 0180381B45 Repair Station, select the TJ-65 mini-thermojet hand piece. On either unit, adjust the temperature control to 700 degrees F. (370 degrees C), and adjust the airflow to a minimum setting. Airflow can vary due to component density.

- To remove a chip component, select a hot-air hand piece and position the nozzle of the hand piece approximately 1/8" above the component to be removed. Begin applying the hot air. Once the solder reflows, remove the component using a pair of tweezers. Using solder wick and a soldering iron or a power desoldering station, remove the excess solder from the pads.

- To replace a chip component using a soldering iron, select the appropriate micro-tipped soldering iron and apply fresh solder to one of the solder pads. Using a pair of tweezers, position the new chip component in place while heating the fresh solder. Once solder wicks onto the new component, remove the heat from the solder. Heat the remaining pad with the soldering iron and apply solder until it wicks to the component. If necessary, touch up the first side. All solder joints should be smooth and shiny.
- To replace a chip component using hot air, select the hot-air hand piece and reflow the solder on the solder pads to smooth it. Apply a drop of solder paste flux to each pad. using a pair of tweezers, position the new component in place. Position the hot-air hand piece approximately 1/8" above the component and begin applying heat. Once the solder wicks to the component, remove the heat and inspect the repair. All joints should be smooth and shiny.

## 5.0 Disassembling and Reassembling the Radio — General

For disassembly or reassembly of the radio, it is important to pay particular attention to all the snaps and tabs, and how parts align with each other.

The following tools are required for disassembling the radio:

- Phillips screwdriver
- Flat head screwdriver
- Chassis Opener
- Crab Eye Nut Opener
- Tweezers

If a unit requires more complete testing or service than is customarily performed at the basic level, send this unit to a Motorola Authorized Service Center.

## 6.0 Radio Disassembly — Detailed

### 6.1 Front Cover from Chassis Disassembly

1. Turn off the radio.
2. Unlatch the battery latch at the bottom of the radio (see “Figure 2-1”). Remove the battery by gently lifting the hilt of the battery, nearest to the battery latch, away from the housing.

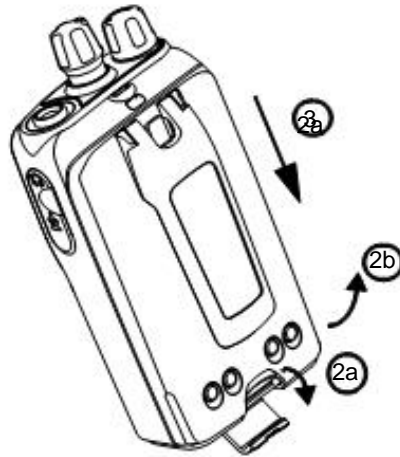

Figure 2-1

3. Slide the battery downwards to remove the battery.
4. Remove the antenna by unscrewing it (see “Figure 2-2”).
5. Pull the On/Off Volume and Channel knobs out of their shafts using the Chassis Opener (see “Figure 2-2”).

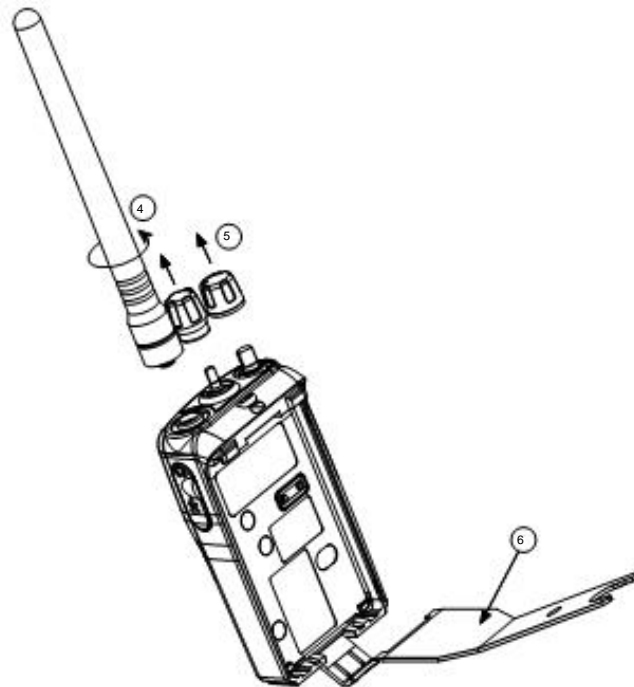

Figure 2-2

6. Insert the Chassis Opener at the bottom of the radio, between the chassis and housing (see “Figure 2-2”). Lift the chassis gently. Be careful not to damage the housing or the O-ring underneath.
7. Lift rear chassis away from the front cover. Be careful not to damage the speaker wire underneath.

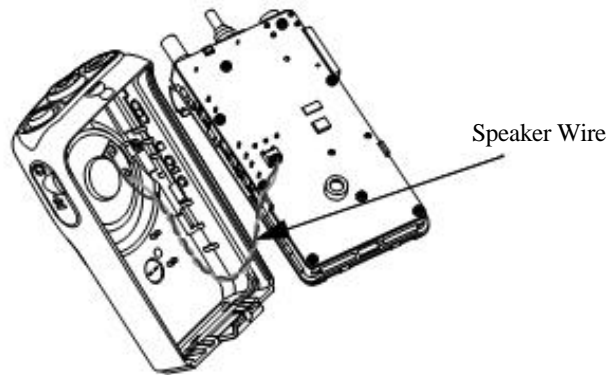

Figure 2-3

8. Slide the rear chassis downwards, and away from the front cover.
9. Remove the speaker connector, which connects between the PC Board and the internal speaker on front cover (see “Figure 2-4”).

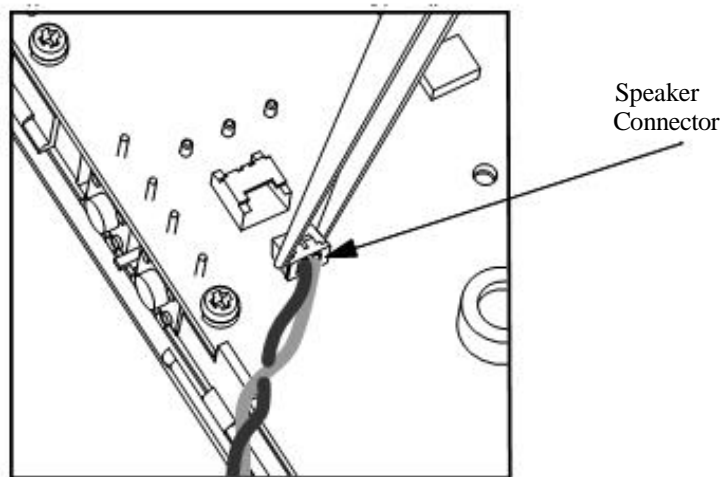

Figure 2-4

**NOTE** Proceed to perform steps 10, 11, and 12 only if there is a need to replace the latch.

10. Remove the latch pad from right slot space.
11. With the battery latch on the housing, push the shaft in the housing slot to the right (see “Figure 2-5”).

- Slide the battery latch shaft out from the latch.

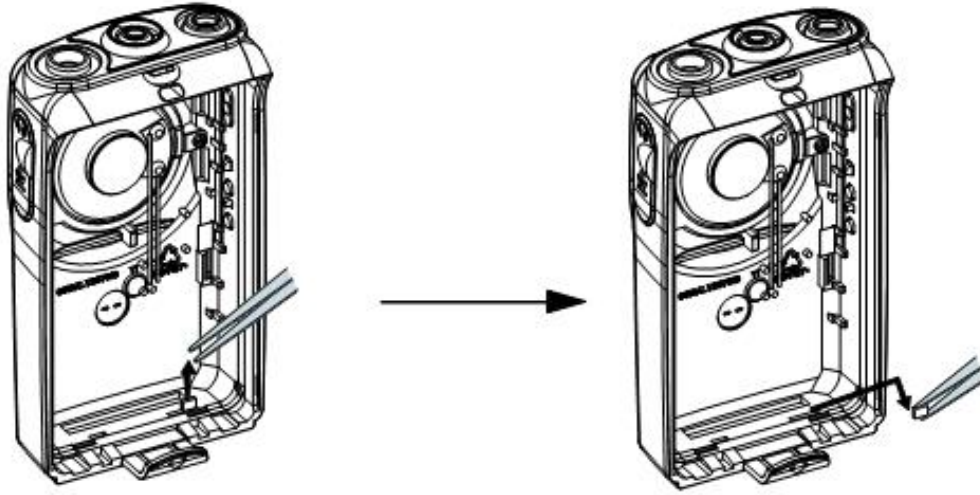

Figure 2-5

**NOTE** Proceed to perform steps 13, 14, and 15 only if there is a need to replace the speaker, speaker bracket or speaker felt.

- Unscrew the speaker bracket from the housing (see “Figure 2-6”).
- Remove the speaker from on top of the speaker felt with a flat head screwdriver.
- Remove the speaker felt from the grille area.

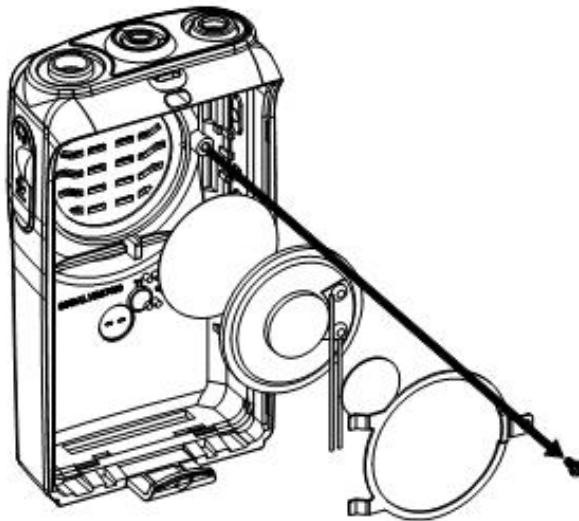

Figure 2-6

## 6.2 PC Board Disassembly

1. Remove the audio jack seal.
2. Remove the 10 screws which hold the PC board to the diecast.
3. Next, remove the 2 nuts on the On/Off Volume and Channel knobs shafts with the Crab Eye Nut Opener.
4. The PC board can now be removed from the rear diecast.
5. The completely disassembly PC board is shown in “Figure 2-7”.

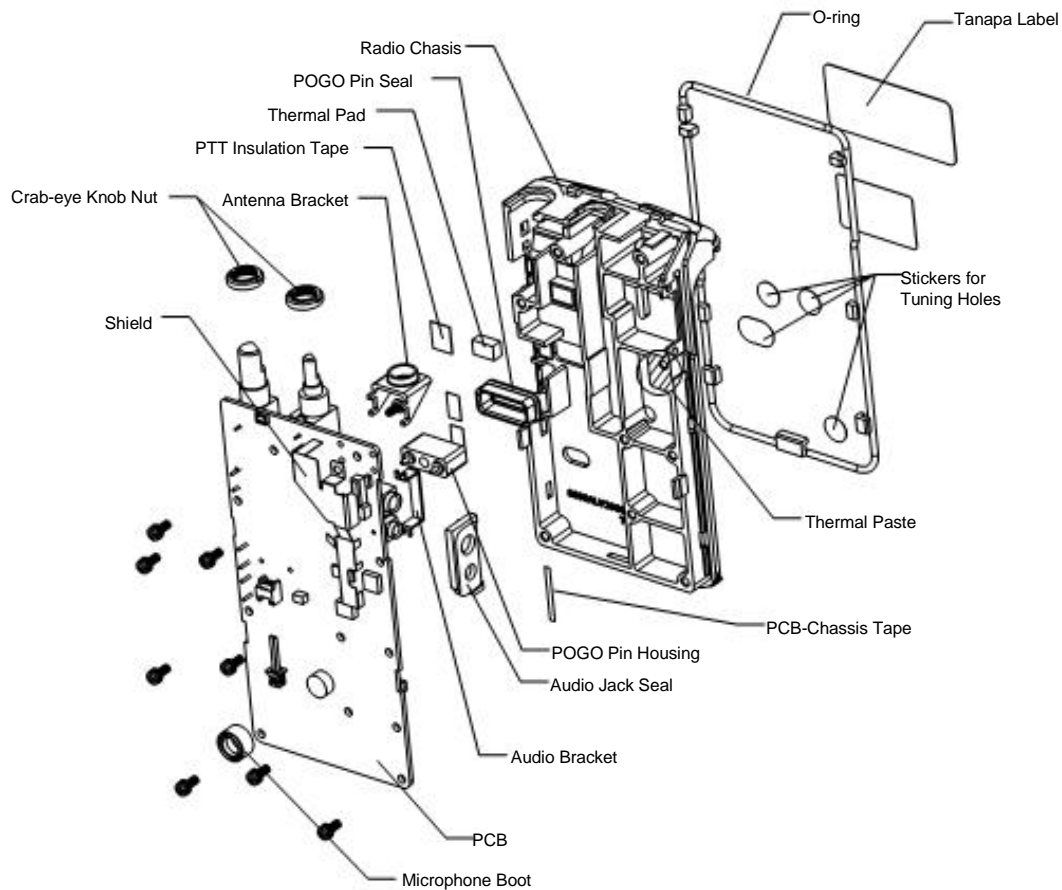

Figure 2-7 Completely Disassembled PC Board

## 7.0 Radio Reassembly — Detailed

### 7.1 PC Board Reassembly

1. Place the PC board on the rear diecast.
2. Tighten the screws and the nuts on the two knobs.
3. Replace the audio jack seal.



## 7.2 Chassis and Front Cover Reassembly

**NOTE** Proceed to perform steps 1, 2, 3 and 4 only if there is a need to replace the speaker, speaker bracket or speaker felt.

1. Place the speaker felt onto the grille area (see “Figure 2-8”).
2. Place the speaker on top of the felt.

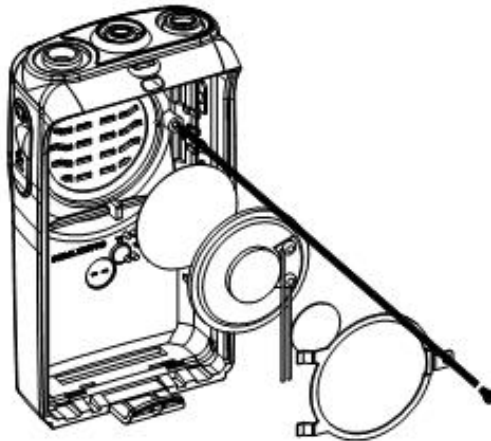

Figure 2-8

3. Stick the speaker poron pad onto the back of speaker magnet.
4. Place the speaker bracket and screw the bracket to the housing.

**NOTE** Proceed to perform steps 5, 6, 7 and 8 only if there is a need to replace the latch.

5. Slot the battery latch shaft into the latch (see “Figure 2-9”).

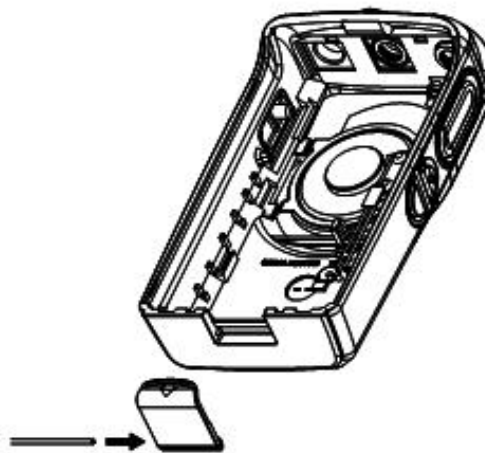

Figure 2-9

6. Place the latch onto the housing, with the shaft protruding on the right side of the latch (see “Figure 2-10”).

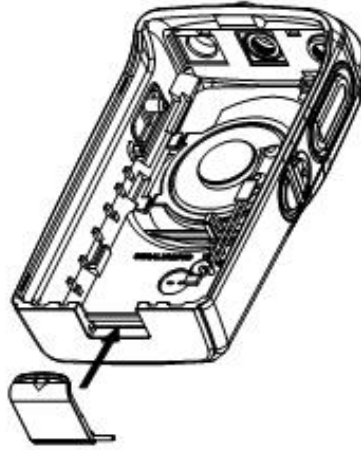

Figure 2-10

7. With the battery latch placed on the housing, push the shaft in the housing slot to the left (see “Figure 2-11”).

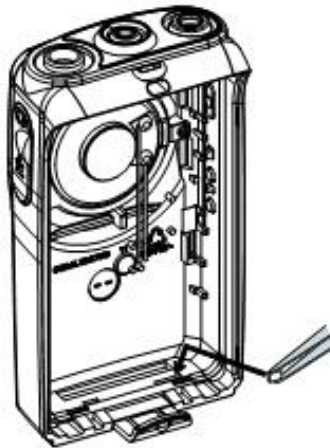

Figure 2-11

8. Place the small latch pad onto the right slot space (see “Figure 2-11”).

9. Connect the internal speaker connector to the PC board (“see “Figure 2-12”).

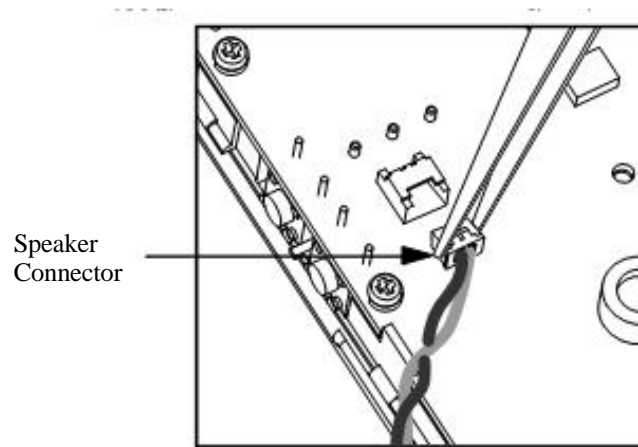

Figure 2-12

10. Place the diecast into the front housing (see “Figure 2-13”).



Figure 2-13

11. Snap the front housing cover firmly into place on the rear diecast .
12. Attach the battery.
13. Attach the On/Off Volume Knob, Channel Knob and Antenna.

## 8.0 Mechanical View and Parts List

### 8.1 Exploded View and Parts List

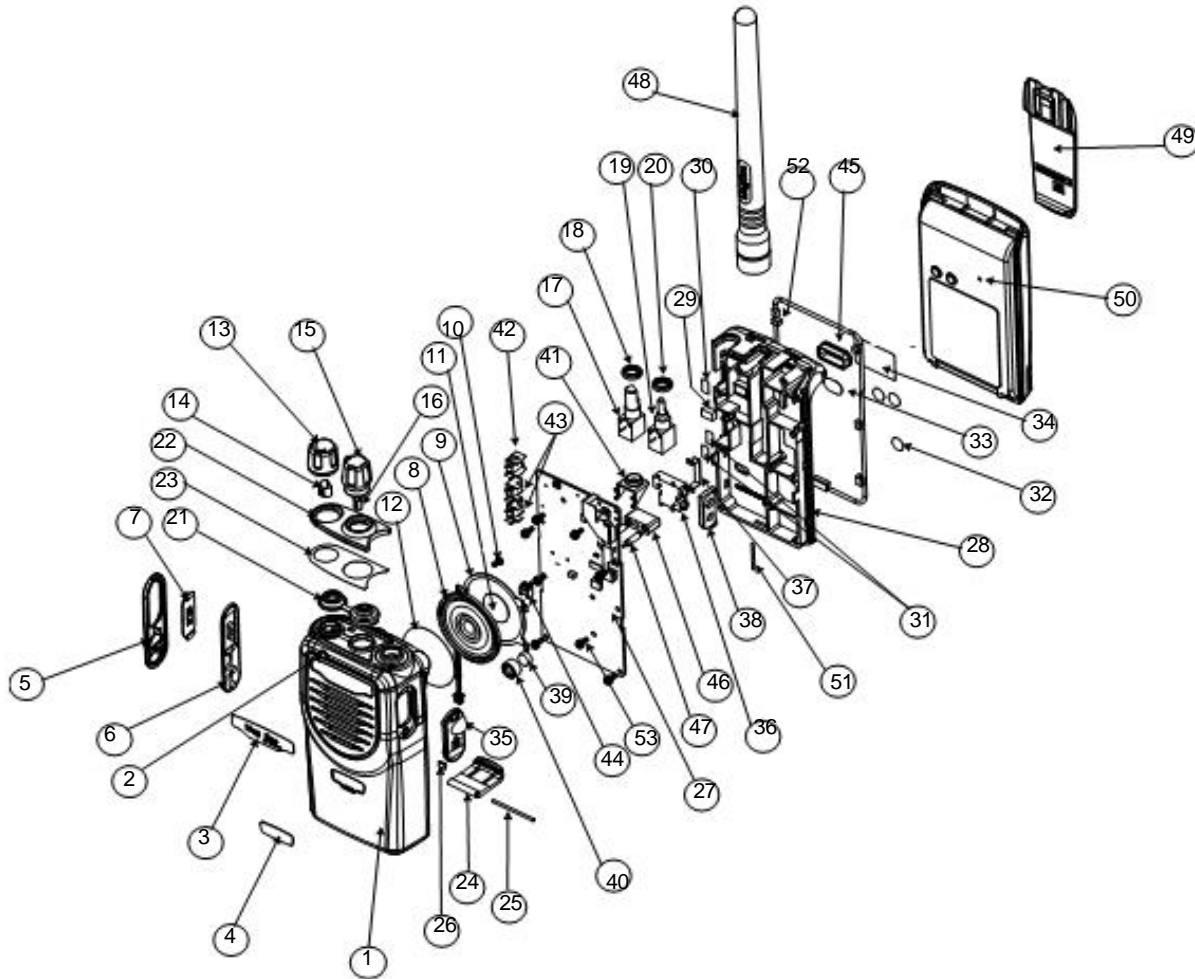

Figure 2-14 Exploded View

Table 2-1 Parts List

Reference No	Part No	Part Name	Qty
1	PMDN4001_R	Front Housing	1
2		Lightpipe	1
3	PMDN4002_R	Mag One™ By Motorola Nameplate	1
4	PMDN4004_R	A8 Nameplate	1
5	PMDN4009_R	PTT Escutcheon	1

Table 2-1 Parts List

Reference No	Part No	Part Name	Qty
6	PMDN4007_R	PTT Rubber	1
7	PMDN4010_R	PTT Bezel	1
8	PMDN4011_R	Speaker & Cable (non-EPP)	1
	PMDN4067_R	Speaker & Cable (EPP)	1
9	PMDN4012_R	Speaker Bracket	1
10		Speaker Bracket Screw	1
11	PMDN4013_R	Speaker Poron Pad	1
12	PMDN4046_R	Speaker Felt	1
13	PMDN4014_R	Volume Knob	1
14		Volume Knob D-Clip (D: 6.0)	1
15	PMDN4015_R	Channel Knob	1
16		Channel Knob D-Clip (D: 3.5)	1
17	PMDN4016_R	Volume Potentiometer	1
18		Crab-Eye Knob Nut	1
19	PMDN4017_R	Channel Potentiometer	1
20		Crab-Eye Knob Nut	1
21	PMDN4018_R	Channel & Volume Top Seal	1
22	PMDN4019_R	Top Escutcheon 16 Channels	1
23		Top Adhesive	1
24	PMDN4023_R	Battery Latch	1
25		Battery Latch Shaft	1
26		Battery Latch Tape	1

Table 2-1 Parts List

Reference No	Part No	Part Name	Qty
27	PMDD4000_R <sup>†</sup>	136 - 150 MHz 5W PC Board (EPP)	1
	PMDD4001_R*	150 - 174 MHz 5W PC Board (non-EPP)	1
	PMDD4005_R <sup>†</sup>	150 - 174 MHz 5W PC Board (EPP)	1
	PMDD4006_R*	148 - 174 MHz 5W PC Board (non-EPP)	1
	PMDD4007_R <sup>†</sup>	148 - 174 MHz 5W PC Board (EPP)	1
	PMDE4000_R <sup>†</sup>	403 - 425 MHz 5W PC Board (EPP)	1
	PMDE4001_R*	450 - 470 MHz 4W PC Board (non-EPP)	1
	PMDE4005_R <sup>†</sup>	450 - 470 MHz 4W PC Board (EPP)	1
28	PMDN4068_R	Radio Chassis (EPP)	1
	PMDN4024_R	Radio Chassis (non-EPP)	1
29		Thermal Pad	1
30		PTT Insulation Tape	1
31		Insulation Tape	2
32	PMDN4028_R	Tuning Hole Sticker (Small)	2
33	PMDN4029_R	Tuning Hole Sticker (Big)	2
34	PMDN4047_R	Moto Caution Label	1
35	PMDN4030_R	Dust Cover	1
36	PMDN4031_R	Audio Jack	1
37		Audio Bracket	1
38	PMDN4032_R	Audio Jack Seal	1
39	PMDN4033_R	Microphone	1
40		Microphone Boot	1
41	PMDN4034_R	Antenna Bracket	1
42	PMDN4035_R	PTT Tact Switch	1
43	PMDN4056_R	Programming Button Tact Switch	2
44	PMDN4036_R	Speaker Connector	1
45	PMDN4037_R	Pogo Pin Seal	1
46		Pogo Pin Housing	1
47		Pogo Pin	2

Table 2-1 Parts List

Reference No	Part No	Part Name	Qty
48	PMAD4050_R	Mag One™ 136-150MHz Antenna	1
	PMAD4051_R	Mag One™ 150-174MHz Antenna	1
	PMAE4019_R	Mag One™ 403-425MHz Antenna	1
	PMAE4020_R	Mag One™ 450-470MHz Antenna	1
	PMAE4028_R	Mag One™ 490-512MHz Antenna	1
49	PMLN4743_	Mag One™ Spring Belt Clip	1
50	PMNN4071_R	Mag One™ NiMH Battery 1200mAH	1
	PMNN4071_RC	Mag One™ NiMH Battery (Chinese Label)	1
51	PMDN4058_R	PCB-Chassis Tape for PMUD2085A_, PMUD2086A_, PMUD2087A_, PMUD2171A_, PMUE2384A_, PMUE2385A_, PMUE2386A_	1
		PCB-Chassis Tape for PMUD2085B_, PMUD2086B_, PMUD2087B_, PMUD2171B_, PMUD2088A_, PMUD2221A	2
		PCB-Chassis Tape for PMUE2384B_, PMUE2385B_, PMUE2386B_, PMUE2387A_, PMUE2736A_	3
52	PMDN4025_R	O-Ring	1
53	PMDN4027_R	PCB Screw	10

\*boards must be used with PMDN4011\_R and PMDN4024\_R.

† boards must be used with PMDN4067\_R and PMDN4068\_R.

## 9.0 Service Aids

Table 2-2 lists service aids recommended for working on the Mag One™ by Motorola Radios. While all of these items are available from Motorola, most are standard shop equipment items, and any equivalent item capable of the same performance may be substituted for the item listed.

Table 2-2 Service Aids

Motorola Part No.	Description	Application
PMDN4038_R	Chassis Opener	To disassemble the radio
PMDN4039_R	Crab Eye Nut Opener	To fasten or remove crab-eye nut.
PMDN4040_R	Test Box	Enables connection to the audio/accessory jack.
PMDN4041_R	RF Adapter	Adapts radio antenna port to BNC cabling of test equipment.
PMDN4043_R	Programming/Test Cable	Connects radio to Computer.
PMDN4060_R	Cloning Cable	Allows a radio to be duplicated from a master radio by transferring programmed data from the master radio to the other.
PMDN4042_R	Battery Eliminator	Interconnects radio to power supply (red-and-black power cable included).
PMDN4054_R	Antenna Ground Plate	To improve grounding while conducting tuning and measurement.
PMDN4044_R	T-Head Ceramic Tuning Tool	To tune the variable resistor for audio and sub-audio modulation adjustment; tuning points accessible via battery-chassis area.
PMDN4026_R	Flat Ceramic Tuning Tool (1.8mm)	To tune the variable resistor for audio and sub-audio modulation adjustment; requires disassembly of PCB from chassis to get access to tuning point.
PMDN4053_R	Flat Ceramic Tuning Tool (0.9mm)	
	Phillips Head Screwdriver	To remove M2 and M2.6 Phillips screws.
	Flat Head Screwdriver	To remove speaker from speaker felt.
	Tweezers	To remove smaller components i.e. latch pad and speaker connector.
TT907A National Service Technical Guide	Repairing Leadless Component Assemblies	Guide on how to successfully remove and replace surface mount devices.



## 10.0 Test Equipment

Table 2-3 lists test equipment required to service the Mag One™ by Motorola Radios and other twoway radios.

Table 2-3 Recommended Test Equipment

Motorola Part No.	Description	Characteristics	Application
R2600	Communication Analyzer		Frequency/deviation meter and signal generator for wide-range troubleshooting and alignment
R1038	Handheld Multimeter		AC/DC Voltage and current measurements
S1339A/220	RF Millivolt Meter 220V	100mv to 3VRF 100kHz to 1.2GHz	RF Level Measurements

## 11.0 Programming Cable (PMDN4043\_R)

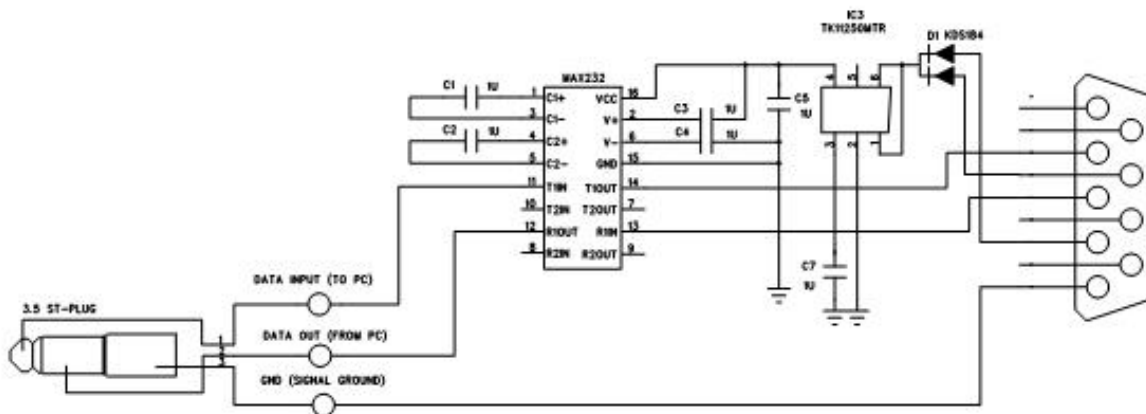

Figure 2-15 Programming Cable Schematic

## 12.0 Cloning Cable (PMDN4060\_R)otes



Figure 2-16 Cloning Cable Schematic

## 13.0 Test Box (PMDN4040\_R)

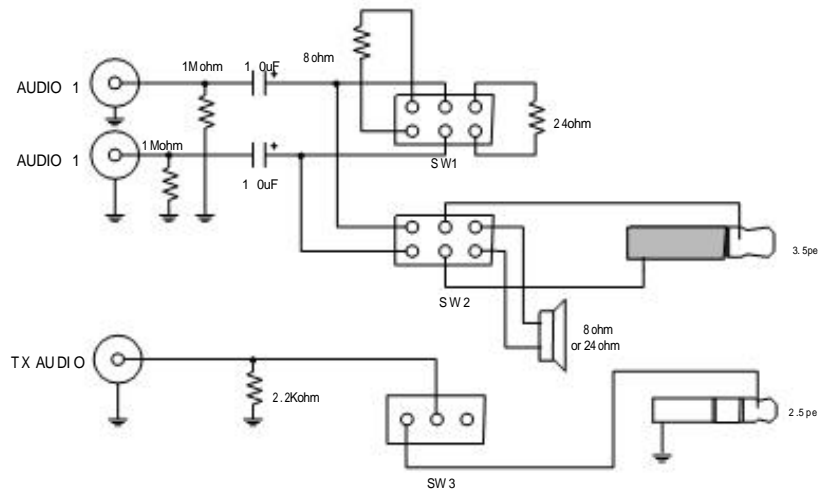

Figure 2-17 Test Box Schematic

---

## Section 3

# RADIO TUNING

### 1.0 Introduction

This chapter provides an overview of the hardware tuning for this Mag One™ Series radio. There is no software tuning required.

In order to perform the manual tuning procedures, the radio needs to be disassembled to the PC Board.

Following are the parameters that can be tuned:-

1. Transmitter Tuning
  - a. High Power Tuning
  - b. Low Power Tuning
  - c. Frequency Tuning
  - d. Modulation Balancing
  - e. Maximum Modulation
  - f. Subtone Modulation
2. Receiver Tuning
  - a. Wide Band Sinad Tuning
  - b. Narrow Band Sinad Tuning
3. PLL Synthesizer Tuning
  - a. Rx PLL Frequency Tuning
  - b. Tx PLL Frequency Tuning

For a list of Service Aids required, refer to Table 2-2 on page 2-16Parts ListParts List

## 2.0 Hardware Tuning Setup and Procedure

### 2.1 Tuning Frequency

Table 3-1 Frequencies Used for Tuning.

Band	Tuning Parameter	Frequency (MHz)
VHF 136 - 150 MHz	PLL Synthesizer	149.975
	Transmitter	136.025
	Receiver	136.025
	Modulation Balance	136.025 (N band)
	Sub-Tone Modulation	149.975 (S band)
	Maximum Modulation	149.975 (S band)
VHF 150 - 174 MHz	PLL Synthesizer	173.975
	Transmitter	150.025
	Receiver	150.025
	Modulation Balance	150.025 (N band)
	Sub-Tone Modulation	173.975 (S band)
	Maximum Modulation	173.975 (S band)
UHF 403 - 425 MHz	PLL Synthesizer	424.975
	Transmitter	403.025
	Receiver	403.025
	Modulation Balance	424.975(N band)
	Sub-Tone Modulation	403.025(N band)
	Maximum Modulation	403.025(N band)
UHF 450 - 470 MHz	PLL Synthesizer	469.975
	Transmitter	450.025
	Receiver	450.025
	Modulation Balance	469.975(N band)
	Sub-Tone Modulation	450.025(N band)
	Maximum Modulation	450.025(N band)

### 2.2 Preparation Before Tuning (refer to Figure 3-1)

1. Set Power Supply to 7.5V and then connect to the radio.
2. Connect the connector and ground plate to the radio antenna port.

3. Connect the radio to the test equipment.

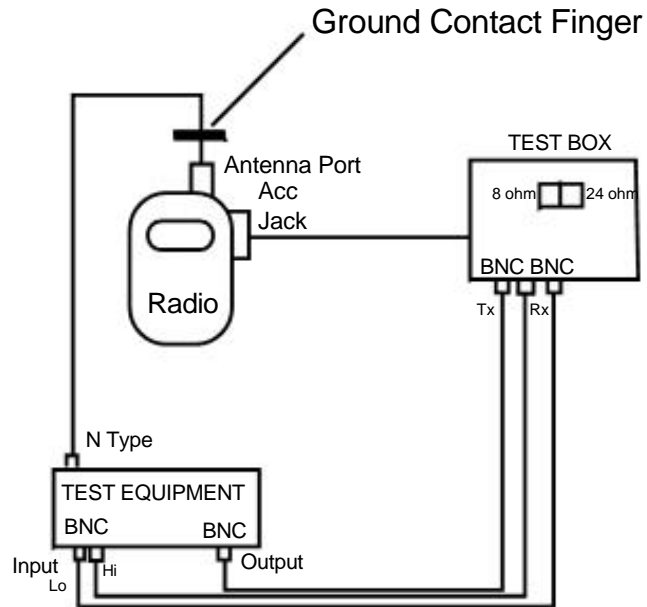

Figure 3-1 Radio Tuning Setup

NOTE On the Test Box, select 8 ohm resistance when using with PMUD2085A\_, PMUE2384A\_. For all other kits, please select 24 ohm resistance.

NOTE The radio may need to be disassembled to the PC board level to access certain tuning ports. For disassembly, refer to "Radio Disassembly — Detailed" on page 2-5

## 2.3 Transmitter Tuning

### 2.3.1 High Power

1. Connect the radio to power meter.
2. Set the radio to the appropriate tuning frequency (refer to Table 3-1).
3. Key up the radio.

- Using the ceramic tool, adjust R425 to tune high power (refer to Figure 3-2).

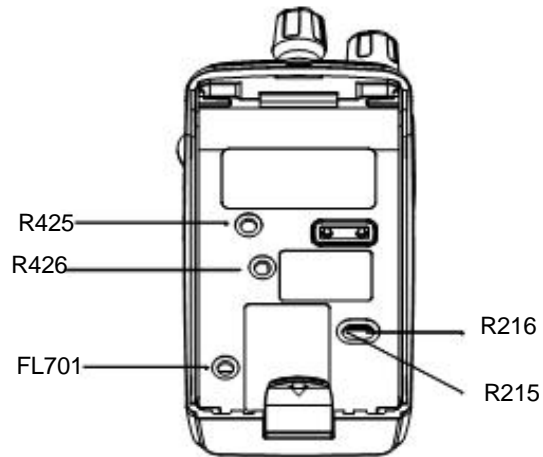

Figure 3-2 Tuning Ports

### 2.3.2 Low Power

- Connect the radio to power meter.
- Set the radio to the appropriate tuning frequency (refer to Table 3-1).
- Key up the radio.
- Using the ceramic tool, adjust R426 to tune low power (refer to Figure 3-2).

### 2.3.3 Frequency Tuning

- Set the radio to the appropriate tuning frequency (refer to Table 3-1).
- Using the ceramic tool, adjust FL701 to tune the frequency (refer to Figure 3-2).

### 2.3.4 Modulation Balancing

- Set the radio to the appropriate tuning frequency (refer to Table 3-1).
- On the test equipment, set the following configurations:
  - Audio bandwidth: 0.25Hz to 15,000Hz.
  - De-emphasis: Off
  - FM: Peak negative
- Using the Audio Analyzer, inject a 0.3kHz tone to the radio through the test box.
- Key up the radio.

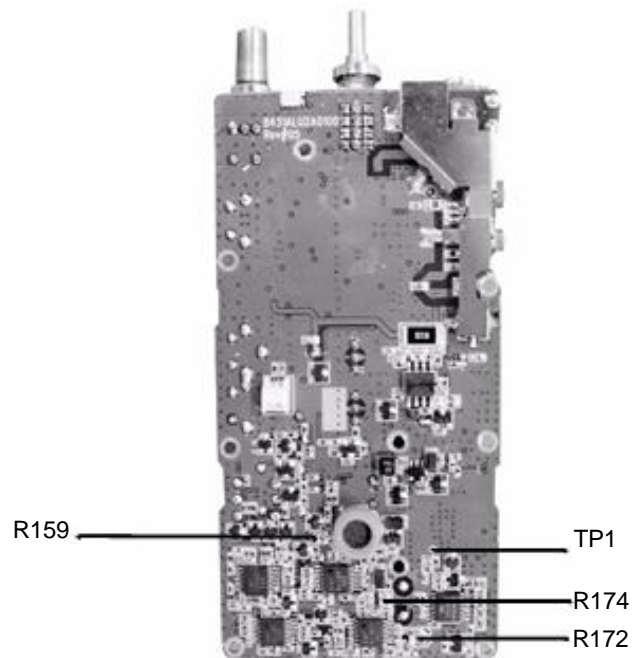

Figure 3-3 Top Side of PCB

5. Using the ceramic tool, adjust R174 (refer to Figure 3-3) to modulation balance as per Figure 3-4.

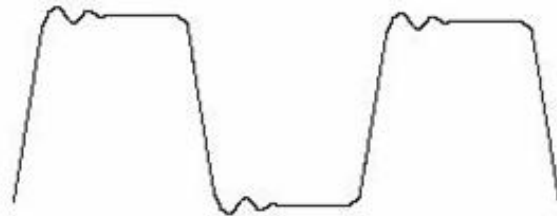

Figure 3-4

**Caution**

Improperly tuned modulation balance can cause errors in Tx sub-tone modulation.

### 2.3.5 Maximum Modulation

1. Set the radio to the appropriate tuning frequency (refer to Table 3-1).
2. On the test equipment, set the following configurations:
  - Audio bandwidth: 0.25Hz to 15,000Hz
  - De-emphasis: Off
  - FM: Peak negative
3. Using the Audio Analyzer, input a 1kHz tone + 67Hz subtone, 120mV to the radio through the test box.
4. Key up the radio.
5. Using the ceramic tool, adjust R159 to tune maximum modulation between  $2.4 \pm 0.02\text{KHz}$  for narrow band or under 5KHz for wide band (refer to Figure 3-3).

### 2.3.6 Subtone Modulation

1. Set the radio to the appropriate tuning frequency (refer to table3-1).
2. On the test equipment set the following configuration
  - Audio bandwidth: 0.25Hz to 15,000Hz
  - De-emphasis: Off
  - FM: Peak negative
3. Program radio subtone to 67Hz (CTCSS).
4. Key up the radio.

Table 3-2 Subtone Modulation Configurations

Band	U1, U2	V1, V2
Subtone Level	$0.42 \pm 0.02\text{kHz}$	$0.96 \pm 0.02\text{kHz}$

5. Using the ceramic tool, adjust R172 to tune subtone modulation to the configurations in Table 3-2.

## 2.4 Receiver Tuning

### 2.4.1 Wide Band Sinad Tuning

1. Set the radio to the appropriate tuning frequency (refer to Table 3-1).
2. Set RF Signal Generator level to -47dBm at 1 kHz tone, 60% of the deviation.
3. Find the SINAD level 7 of the radio to decrease RF Signal Generator level.
4. Using the ceramic tool, adjust R215 clockwise to off the audio output.
5. Then adjust R215 counterclockwise at the point where the Audio Frequency signal appears (refer to Figure 3-2).

### 2.4.2 Narrow Band Sinad Tuning

1. Set the radio to the appropriate tuning frequency (refer to Table 3-1).
2. Set RF Signal Generator level to -47dBm at 1 kHz tone, 60% of the deviation.
3. Find the SINAD level 7 of the radio to decrease RF Signal Generator level.
4. Using the ceramic tool, adjust R216 clockwise to off the audio output (refer to Figure 3-2).



5. Then adjust R216 counterclockwise at the point where the Audio Frequency signal appears.

### 2.4.3 PLL Synthesizer Tuning

#### Rx PLL Frequency Tuning

1. Set the radio to the appropriate tuning frequency (refer Table 3-1).
2. Detect output voltage at test point TP1 (refer to Figure 3-3).
3. Using the ceramic tool, adjust C710 to tune the voltage to 5.0V +/-0.1V(refer to Figure 3-5).

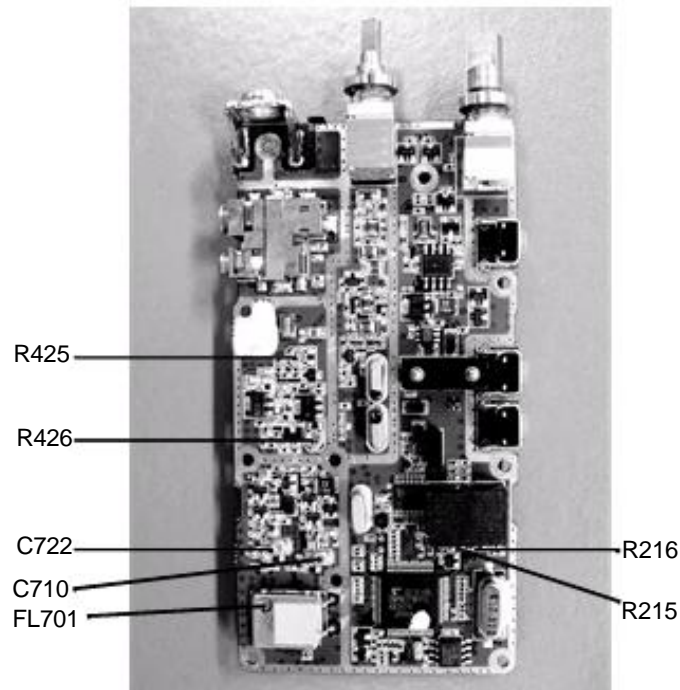

Figure 3-5 Bottom Side of PCB

#### Tx PLL Frequency Tuning

1. Set the radio to the appropriate tuning frequency (refer Table 3-1).
2. Detect output voltage at test point TP1.
3. Using the ceramic tool, adjust C722 to tune the voltage below 5.0V +/-0.1V (refer to Figure 3-5).

## Notes

## Section 4

# RADIO PROGRAMMING

### 1.0 Introduction

The radios can be programmed using the Customer Programming Software (CPS).

### 2.0 Programming Your Radio

#### 2.1 Overview of the Programming Process

To prepare properly programmed radios for your customers, you should

1. program your radio with all the necessary parameters, as required by your customers, and then
2. clone these parameters over to all your customer's radios.

#### 2.2 Cloning Radio Parameters to User Radios

Cloning duplicates the contents of Radio 1 (master radio) into Radio 2 (slave radio).

#### 2.3 Parameters which are cloned

- Radio Configuration parameters
- Conventional Personality parameters

#### 2.4 Parameters which are not cloned

- Unit Serial Number.
- Model Number

#### 2.5 To Clone a Radio

Cloning duplicates the contents of your radio (master radio) into your customer's radio (slave radio). Tuning and alignment information are not affected by cloning.

##### 2.5.1 Setting Up the Master Radio

1. Turn off the radio.
2. Press and hold Programmable Button 1 (the top programmable button) and turn on the radio. Keep pressing the Programmable Button 1 until beep is heard twice.
3. Release Programmable Button 1. Notice that the LED changes to RED.

### 2.5.2 Setting Up the Slave Radio

1. Turn off the radio.
2. Press and hold Programmable Button 1 (the top programmable button) and turn on the radio. Keep pressing Programmable Button 1 until the beep is heard three times.
3. Release Programmable Button 1. Notice that the LED changes to GREEN.

### 2.5.3 Radio to Radio Cloning Procedures

1. Connect the cloning cable to both the Master and Slave radio.
2. Press and release Programmable Button 1 of the Slave radio.
3. Press and release Programmable Button 1 of the Master radio.
4. The LED for both radios show flashing orange during cloning.
5. Once cloning is completed, an 'Out Chirp' alert tone can be heard from both radios.
6. Disconnect radios from the cloning cable. They are now ready for operation.

## 2.6 Error Conditions

An error may occur when cloning a radio. When this happens, the radio sounds a Faulty Condition Alert tone and shows a Flashing Orange LED momentarily.

**NOTE** The LED will illuminate in RED and the radio will keep transmitting if the cloning cable is still connected to the radio after cloning is completed. Please disconnect the cloning cable from the radio

## 3.0 CPS Programming

The CPS is designed for use in the Windows 98/NT/2000/XP and above environment. An Installation instruction manual is contained within each CPS kit.

Description	Kit Number
Mag One™ Customer Programming Software (CD)	RVN5079_

Refer to the diagram below for the programming setup.

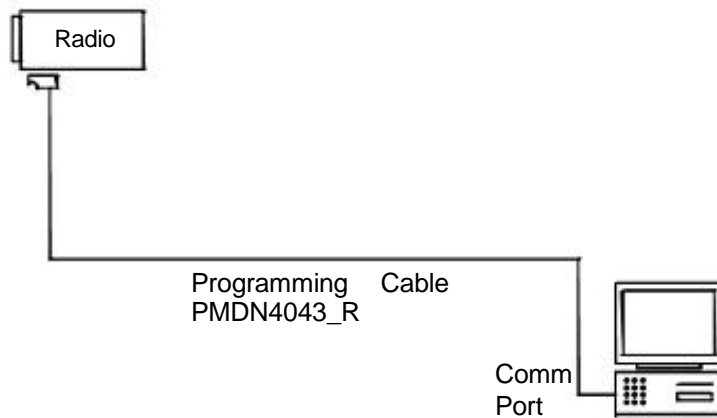

Figure 4-1 CPS Programming Setup

### 3.1 To Read Radio Data to a PC

1. Turn off the radio.
2. Connect the programming cable to the radio.
3. Press and hold Programmable Button 1 (top side button on the radio), then turn on the radio.
4. The radio beeps once. Immediately release Programmable Button 1. The radio's LED illuminates in orange.
5. Click the Read button on the CPS.
6. The CPS shows a reading progress bar.

### 3.2 To Write Data to a Radio

1. Turn off the radio.
2. Connect the programming cable to the radio
3. Press and hold Programmable Button 1 (top side button on radio) then turn on the radio.
4. The radio beeps once. Immediately release Programmable Button 1. The radio's LED illuminates in orange.
5. Click the Write button on the CPS.
6. The CPS shows writing progress bar.

## 4.0 Factory Reset

This feature allows the user to restore the radio to the factory default settings.

1. Press and hold both the PTT and Programmable Button 2 (the lower programmable button), while turning on the radio.
2. The radio emits the Good Key Chirp tone upon completion of the factory reset.

## Notes

## Section 5

# ACCESSORIES

### 1.0 Antennas

PMAD4050_R	Mag One™ 136-150MHz Antenna
PMAD4051_R	Mag One™ 150-174MHz Antenna
PMAE4019_R	Mag One™ 403-425MHz Antenna
PMAE4020_R	Mag One™ 450-470MHz Antenna
PMAE4028_R	Mag One™ 490-512MHz Antenna

### 2.0 Carry Accessories

PMLN4691_R	Mag One™ Belt Clip
PMLN4743_	Mag One™ Spring Belt Clip

### 3.0 Carry Cases

PMLN4741_	Soft Leather Carry Case
PMLN4742_	Hard Leather Carry Case

### 4.0 Chargers

AZPMLN4685_R	Mag One™ Mid-rate Charger Base
AZPMLN4686_R	Mag One™ Mid-rate Charger 110V 60Hz US 2-pin
AZPMLN4687_R	Mag One™ Mid-rate Charger 240V 50Hz UK 3-pin
AZPMLN4688_R	Mag One™ Mid-rate Charger 230V 50Hz EU 2-pin
PMLN4689_R	Mag One™ Mid-rate Charger 220V 50Hz CN 2-pin
PMLN4826_R	Mag One™ Mid-rate Transformer 110V US 2-pin
PMLN4827_R	Mag One™ Mid-rate Transformer 240V UK 3-pin
PMLN4828_R	Mag One™ Mid-rate Transformer 230V EU 2-pin
PMLN4830_R	Mag One™ Mid-rate Transformer 220V CN 2-pin

### 5.0 Batteries

PMNN4071_R	Mag One™ NiMH Battery, 1200mAH
PMNN4071_RC	Mag One™ NiMH Battery 1200mAH (Chinese Label)

## 6.0 Audio Accessories

PMMN4008_	Remote Speaker Microphone
PMLN4442_	Earbud with in-line microphone and PTT/VOX switch
PMLN4443_	Ear Receiver with in-line microphone and PTT/VOX switch
PMLN4445_	Ultra Lightweight Headset with in-line PTT/VOX switch
PMLN4294_	Earbud with microphone and PTT combined
PMLN4605_	Clear Acoustic Tube (replacement kit)
PMLN4606_	2-Wire Surveillance kit with Clear Acoustic Tube
PMLN4658_	D-shell Earset with Boom Microphone with PTT/VOX switch

## 7.0 Publications

6815549H01	A8 User Guide (APAC English)
6815553H01	A8 User Guide (APAC Chinese)
6815692H01	Mag One™ by Motorola Series Radio Service Manual, English
6815693H01	Mag One™ by Motorola Series Radio Service Manual, Chinese
6816103H01	Mag One™ Warranty Card
6816309H01	Mag One™ CPS User Guide
6816189H01	Mag One™ Mid-Rate Charger User Guide (APAC)

## 8.0 Service Kits

PMDN4038_R	Chassis Opener
PMDN4039_R	Crab Eye Nut Opener
PMDN4040_R	Test Box
PMDN4041_R	RF Adapter
PMDN4042_R	Battery Eliminator
PMDN4043_R	Programming Cable
PMDN4060_R	Cloning Cable
PMDN4054_R	Antenna Ground Plate
PMDN4044_R	T-Head Ceramic Tuning Tool
PMDN4053_R	Flat Ceramic Tuning Tool (0.9mm)
PMDN4026_R	Flat Ceramic Tuning Tool (1.8mm)



## Section 6

### MODEL CHART AND TEST SPECIFICATION

NOTE For specific models and options configuration, please refer to the Price Pages available on Motorola Online at <https://businessonline.motorola.com/> .

#### 1.0 VHF Band 1 Information (136-150 MHz)

A8 136-150 MHz VHF							
Model						Description	
LAH84JDC8AA4AN						A8 136-150 MHz, 5W, 12.5/25K-16CH	
Option STDCHG0027AE						Standard Mid-Rate Charger 120V US Plug 60Hz	
Option Q665AG						Mid-Rate Charger 230V EURO Plug 50Hz	
Option Q312BD						Mid-Rate Charger Base Only - Argentina	
Option Q91AB						Mid-Rate Charger 240V UK Plug 50Hz	
Option H951FF						Delete Standard Charger	
Item						Description	
X	X	X	X	X	X	PMUD2088_AL	A8 136-150 MHz 5W 12.5/25K - 16CH
X	X	X	X	X	X	PMAD4050_	VHF 136-150MHZ Antenna
X	X	X	X	X	X	PMNN4071_	NiMH Battery
X	X	X	X	X	X	PMLN4691_	Belt Clip
	X					PMLN4685_	Mag One Mid-Rate Charger Base
	X					2515945H01	Mag One Mid-Rate Transformer 110V US 2-pin
		X				PMLN4685_	Mag One Mid-Rate Charger Base
		X				2515943H01	Mag One Mid-Rate Transformer 230V EU 2-pin
			X			PMLN4685_	Mag One Mid-Rate Charger Base
			X			2515942H01	Mag One Mid-Rate Transformer 240V UK 3-pin A8 User
X	X	X	X	X	X	PMLN4739_	Guide ENG/SPAN/POR and Charger manual Safety
X	X	X	X	X	X	68P81095C98	Leaflet - Portable 2-Way Radios

## 2.0 Specifications

### General

	VHF
Frequency:	136-150MHz
Channel Capacity:	16
Power Supply:	7.5 Volts $\pm$ 20%
Dimensions with Standard High Capacity NiMH Battery:	118mm x 56mm x 37mm
Weight with Standard High Capacity NiMH Battery:	350g
Sealing:	Passes rain testing per IPX4 (EN60529=1991)
Shock and Vibration:	Meets MIL STD 810C, D E and F
Dust:	Meets MIL STD 810C, D E and F
Humidity:	Meets MIL STD 810C, D E and F

### Transmitter

	VHF
Channel Spacing	12.5/25 kHz
Freq. Stability (-30°C to +60°C)	0.00025%
Spurs/Harmonics:	-26 dBm
Audio Response: (from 6 dB/oct. Pre-Emphasis, 300 to 3000Hz)	+1, -3 dB
Audio Distortion: @ 1000 Hz, 60% Rated Max. Dev.	<5%
FM Noise:	40dB

### Receiver

Hum and Noise	40 dB
Audio Distortion	< 5%
Conducted Emission	-57 dBm
Audio Output @ <5% Distortion	500 mW

All specifications are subject to change without notice.

### 3.0 VHF Band 2 Information (150 - 174 MHz)

A8 150-174 MHz VHF									
Model							Description		
LAH84KDC8AA4AN							A8 150-174 MHz, 5W, 12.5/25K-16CH		
Option STDCHG0027AE							Standard Mid-Rate Charger 120V US Plug 60Hz		
Option Q665AG							Mid-Rate Charger 230V EURO Plug 50Hz		
Option Q312BD							Mid-Rate Charger Base Only - Argentina		
Option Q91AB							Mid-Rate Charger 240V UK Plug 50Hz		
Option H951FF							Delete Standard Charger		
Item							Description		
X	X	X	X	X	X	PMUD2085_AL A8	150-174 MHz 5W 12.5/25K - 16CH		
X	X	X	X	X	X	PMAD4051_	VHF 150-174MHZ Antenna		
X	X	X	X	X	X	PMNN4071_	NiMH Battery		
X	X	X	X	X	X	PMLN4691_	Belt Clip		
	X					PMLN4685_	Mag One Mid-Rate Charger Base		
	X					2515945H01	Mag One Mid-Rate Transformer 110V US 2-pin		
		X				PMLN4685_	Mag One Mid-Rate Charger Base		
		X				2515943H01	Mag One Mid-Rate Transformer 230V EU 2-pin		
			X			PMLN4685_	Mag One Mid-Rate Charger Base		
				X		PMLN4685_	Mag One Mid-Rate Charger Base		
				X		2515942H01	Mag One Mid-Rate Transformer 240V UK 3-pin		
X	X	X	X	X	X	PM_N4739_	A8 User Guide ENG/SPAN/POR and Charger manual		
X	X	X	X	X	X	68P81095C98	Safety Leaflet - Portable 2-Way Radios		

## 4.0 Specifications

### General

	VHF
Frequency:	150-174 MHz
Channel Capacity:	16
Power Supply:	7.5 Volts $\pm$ 20%
Dimensions with Standard High Capacity NiMH Battery:	118mm x 56mm x 37mm
Weight with Standard High Capacity NiMH Battery:	350g
Sealing:	Passes rain testing per IPX4 (EN60529=1991)
Shock and Vibration:	Meets MIL STD 810C, D E and F
Dust:	Meets MIL STD 810C, D E and F
Humidity:	Meets MIL STD 810C, D E and F

### Transmitter

	VHF
Channel Spacing	12.5/25 kHz
Freq. Stability (-30°C to +60°C)	0.00025%
Spurs/Harmonics:	-26 dBm
Audio Response: (from 6 dB/oct. Pre-Emphasis, 300 to 3000Hz)	+1, -3 dB
Audio Distortion: @ 1000 Hz, 60% Rated Max. Dev.	<5%
FM Noise:	40dB

### Receiver

Hum and Noise	40 dB
Audio Distortion	< 5%
Conducted Emission	-57 dBm
Audio Output @ <5% Distortion	500 mW

All specifications are subject to change without notice.

### 5.0 UHF Band 1 Information (403-425MHz)

A8 403-425 MHz UHF									
Model							Description		
LAH84QCC8AA4AN							A8 403-425 MHz, 4W, 12.5/25K-16CH		
Option STDCHG0027AE							Standard Mid-Rate Charger 120V US Plug 60Hz		
Option Q665AG							Mid-Rate Charger 230V EURO Plug 50Hz		
Option Q312BD							Mid-Rate Charger Base Only - Argentina		
Option Q91AB							Mid-Rate Charger 240V UK Plug 50Hz		
Option H951FF							Delete Standard Charger		
Item							Description		
X	X	X	X	X	X	PMUE2387_AL	A8	403-425 MHz 4W 12.5/25K - 16CH	
X	X	X	X	X	X	PMAE4019_		UHF 403-425MHZ Antenna	
X	X	X	X	X	X	PMNN4071_		NiMH Battery	
X	X	X	X	X	X	PMLN4691_		Belt Clip	
	X					PMLN4685_		Mag One Mid-Rate Charger Base	
	X					2515945H01		Mag One Mid-Rate Transformer 110V US 2-pin	
		X				PMLN4685_		Mag One Mid-Rate Charger Base	
		X				2515943H01		Mag One Mid-Rate Transformer 230V EU 2-pin	
			X			PMLN4685_		Mag One Mid-Rate Charger Base	
				X		PMLN4685_		Mag One Mid-Rate Charger Base	
				X		2515942H01		Mag One Mid-Rate Transformer 240V UK 3-pin	
X	X	X	X	X	X	PMLN4739_		A8 User Guide ENG/SPAN/POR and Charger manual	
X	X	X	X	X	X	68P81095C98		Safety Leaflet - Portable 2-Way Radios	

## 6.0 Specifications

### General

	UHF
Frequency:	403-425MHz
Channel Capacity:	16
Power Supply:	7.5 Volts $\pm$ 20%
Dimensions with Standard High Capacity NiMH Battery:	107mm x 58mm x 37mm
Weight: with Standard High Capacity NiMH Battery:	350g
Sealing:	Passes rain testing per IPX4 (EN60529=1991)
Shock and Vibration:	Meets MIL STD 810C, D E and F
Dust:	Meets MIL STD 810C, D E and F
Humidity:	Meets MIL STD 810C, D E and F

### Transmitter

	UHF
Channel Spacing	12.5/25 kHz
Freq. Stability (-30°C to +60°C)	0.00025%
Spurs/Harmonics:	-27 dBm
Audio Response: (from 6 dB/oct. Pre-Emphasis, 300 to 3000Hz)	+1, -3 dB
Audio Distortion: @ 1000 Hz, 60% Rated Max. Dev.	<5%
FM Noise:	40dB

### Receiver

Hum and Noise	40 dB
Audio Distortion	< 5%
Conducted Emission	-57 dBm
Audio Output @ <5% Distortion	500mW

All specifications are subject to change without notice.

7.0 UHF Band 2 Information (450 - 470MHz)

A8 450-470 MHz UHF							
Model						Description	
LAH84RCC8AA4AN						A8 450-470 MHz, 4W, 12.5/25K-16CH	
Option STDCHG0027AE						Standard Mid-Rate Charger 120V US Plug 60Hz	
Option Q665AG						Mid-Rate Charger 230V EURO Plug 50Hz	
Option Q312BD						Mid-Rate Charger Base Only - Argentina	
Option Q91AB						Mid-Rate Charger 240V UK Plug 50Hz	
Option H951FF						Delete Standard Charger	
Item						Description	
X	X	X	X	X	X	PMUE2384AAL A8 4	50-470 MHz 4W 12.5/25K - 16CH
X	X	X	X	X	X	PMAE4020A	UHF 450-470MHZ Antenna
X	X	X	X	X	X	PMNN4071A	NiMH Battery
X	X	X	X	X	X	PMLN4691A	Belt Clip
	X					PMLN4685A	Mag One Mid-Rate Charger Base
	X					2515945H01	Mag One Mid-Rate Transformer 110V US 2-pin
		X				PMLN4685A	Mag One Mid-Rate Charger Base
		X				2515943H01	Mag One Mid-Rate Transformer 230V EU 2-pin
			X			PMLN4685A	Mag One Mid-Rate Charger Base
				X		PMLN4685A	Mag One Mid-Rate Charger Base
				X		2515942H01	Mag One Mid-Rate Transformer 240V UK 3-pin
X	X	X	X	X	X	PMLN4739_	A8 User Guide ENG/SPAN/POR and Charger manual
X	X	X	X	X	X	68P81095C98	Safety Leaflet - Portable 2-Way Radios

## 8.0 Specifications

### General

	UHF
Frequency:	450-470 MHz
Channel Capacity:	16
Power Supply:	7.5 Volts $\pm$ 20%
Dimensions with Standard High Capacity NiMH Battery:	107mm x 58mm x 37mm
Weight: with Standard High Capacity NiMH Battery:	350g
Sealing:	Passes rain testing per IPX4 (EN60529=1991)
Shock and Vibration:	Meets MIL STD 810C, D E and F
Dust:	Meets MIL STD 810C, D E and F
Humidity:	Meets MIL STD 810C, D E and F

### Transmitter

	UHF
Channel Spacing	12.5/25 kHz
Freq. Stability (-30°C to +60°C)	0.00025%
Spurs/Harmonics:	-27 dBm
Audio Response: (from 6 dB/oct. Pre-Emphasis, 300 to 3000Hz)	+1, -3 dB
Audio Distortion: @ 1000 Hz, 60% Rated Max. Dev.	<5%
FM Noise:	40dB

### Receiver

Hum and Noise	40 dB
Audio Distortion	< 5%
Conducted Emission	-57 dBm
Audio Output @ <5% Distortion	500mW

All specifications are subject to change without notice.



### 9.0 UHF Band 4 Information (490 - 512 MHz)

A8 490-512 MHz UHF							
Model						Description	
LAH84TCC8AA4AN						A8 490-512 MHz, 4W, 12.5/25K-16CH	
Option STDCHG0027AE						Standard Mid-Rate Charger 120V US Plug 60Hz	
Option Q665AG						Mid-Rate Charger 230V EURO Plug 50Hz	
Option Q312BD						Mid-Rate Charger Base Only - Argentina	
Option Q91AB						Mid-Rate Charger 240V UK Plug 50Hz	
Option H951FF						Delete Standard Charger	
Item						Description	
X	X	X	X	X	X	PMUE2771AAL A8 4	90-512 MHz 4W 12.5/25K - 16CH
X	X	X	X	X	X	PMAE4028A	UHF 490-512MHZ Antenna
X	X	X	X	X	X	PMNN4071A	NiMH Battery
X	X	X	X	X	X	PMLN4691A	Belt Clip
	X					PMLN4685A	Mag One Mid-Rate Charger Base
	X					2515945H01	Mag One Mid-Rate Transformer 110V US 2-pin
		X				PMLN4685A	Mag One Mid-Rate Charger Base
		X				2515943H01	Mag One Mid-Rate Transformer 230V EU 2-pin
			X			PMLN4685A	Mag One Mid-Rate Charger Base
				X		PMLN4685A	Mag One Mid-Rate Charger Base
				X		2515942H01	Mag One Mid-Rate Transformer 240V UK 3-pin
X	X	X	X	X	X	PMLN4739_	A8 User Guide ENG/SPAN/POR and Charger manual
X	X	X	X	X	X	68P81095C98	Safety Leaflet - Portable 2-Way Radios

## 10.0 Specifications

### General

	UHF
Frequency:	490-512 MHz
Channel Capacity:	16
Power Supply:	7.5 Volts $\pm$ 20%
Dimensions with Standard High Capacity NiMH Battery:	107mm x 58mm x 37mm
Weight: with Standard High Capacity NiMH Battery:	350g
Sealing:	Passes rain testing per IPX4 (EN60529=1991)
Shock and Vibration:	Meets MIL STD 810C, D E and F
Dust:	Meets MIL STD 810C, D E and F
Humidity:	Meets MIL STD 810C, D E and F

### Transmitter

	UHF
Channel Spacing	12.5/25 kHz
Freq. Stability (-30°C to +60°C)	0.00025%
Spurs/Harmonics:	-27 dBm
Audio Response: (from 6 dB/oct. Pre-Emphasis, 300 to 3000Hz)	+1, -3 dB
Audio Distortion: @ 1000 Hz, 60% Rated Max. Dev.	<5%
FM Noise:	40dB

### Receiver

Hum and Noise	40dB
Audio Distortion	<5%
Conducted Emission	-57 dBm
Audio Output @ <5% Distortion	500mW

All specifications are subject to change without notice.

## GLOSSARY OF TERMS

Term	Definition
Busy Channel Lockout (BCLO)	If BCLO is activated, the radio will check for channel activity before transmitting. If activity is detected, transmission is prohibited. For carrier squelch mode, radio will not transmit, if it is receiving carrier. For coded squelch mode, it will not transmit, if it is receiving carrier with different PL/DPL code.
Carrier	An electromagnetic signal that is transmitted on a selected frequency for the purpose of carrying voice or data transmissions along with it. Carrier can then be received by all radios listening on that frequency.
CD	Compact Disk.
Channel	A single path separated by frequency or time divisions used for transmitting and/or receiving voice and/or data.
Codeplug	A solid-state chip inside a radio where the radio's personality data is stored.
CPS	Acronym for Customer Programming Software. Licensed Motorola software used to program two-way radios with a unique set of features.
Frequency	(a) The location of the center of a channel of operation in the radio spectrum. Measured in Megahertz (MHz). (b) A computer speed. Measured in Megahertz (MHz).
Model Number	The model number identifies the type of radio. This information is stored in the radio's codeplug.
Normal Scan	For Normal Scan, the radio assigns equal priority to all members in the Scan List selected for the current channel. When the radio is scanning a Scan List (Active Scan), all scan list members (including the Home Channel) will be allocated equal time to be scanned. For example, if the Home Channel is H1, and the Scan List Members are Nn, then the scanning sequence is: N1, N2, N3, ..., H1, N1, N2, ..., etc.
PLL	Phase-Locked Loop: a circuit in which an oscillator is kept in phase with a reference, usually after passing through a frequency divider.
Priority Scan	For Priority Scan, the radio assigns the highest priority to the channel defined in the CPS as Priority Channel. When the radio is scanning a Scan List (Active Scan), 50% of the scans are targeted at the Priority Channel. For example, if the Priority Channel is P1, and the non-priority Scan List Members are Nn, then the scanning sequence is: P1, N1, P1, N2, P1, N3, P1, N4, P1, N5, etc.
Program	The transfer of CPS information from the computer's temporary memory (RAM) to the radio.
PTT	Push-To-Talk: the switch located on the left side of the radio which, when pressed, causes the radio to transmit.
RESET	Reset line: an input to the microcontroller that restarts execution.
Reverse Burst / Turn Off Code	Causes a Tone Private Line (TPL) or Digital Private Line (DPL) code to be transmitted at the end of a transmission - once PTT is released, and while operating on the current channel. This sub-audible tone causes the receiving radio to mute its speaker before loss of a carrier is detected. Muting the speaker eliminates unwanted noise (squelch tail) during loss of carrier detection.

Term	Definition
ROM	Read Only Memory.
Scan List	The Scan List determines which channels the radio scans, when operating in the Scan Mode, on the current channel.
Scan List Member	The Scan List allows you to select the grouping of channels that make up the current Scan List Member channels. This grouping of Scan List Member channels can then be scanned for transmission activity - one at a time, when the radio is in Scan Mode. A Scan List can have a maximum of 16 Scan List Members. Scan List Member scanning priority is definable.
Scan Mode	When the radio is in one of the two Scan States: Active Scan and Landed Scan. This mode is initiated when the programmable SCAN button is pressed.
Serial Number	Each radio has its own unique serial number. This information is stored in the radio's codeplug.
Software	Computer programs, procedures, rules, documentation, and data pertaining to the operation of a system.
Squelch	Muting of audio circuits when received signal levels fall below a pre-determined value.
Tone Private Line (TPL)	Transmitted when the receiving radio is to only receive calls from radios with specific TPL codes, this creates communications groups while operating in Conventional Dispatch mode. TPL allows for more use and privacy on a frequency. TPL is transmitted at a sub-audible (not able to be heard) frequency. Also known as CTCSS.
Tx Frequency	A designated frequency used when transmitting carrier for the current channel.
μC	Microcontroller.
UHF	Ultra High Frequency.
VHF	Very High Frequency.





©2007 by Motorola, Inc. All rights reserved.  
Mag One by Motorola is registered in the U.S. Patent and Trademark Office.  
All other product or service names are the property of their respective owners.

Motorola, Inc.  
8000 West Sunrise Boulevard  
Plantation, FL 33322  
U.S.A.

March, 2007